

Name: _____

COLUMBUS'S EXPEDITIONS

Use the map on this page to complete the activities below. For help, you can refer to pages 138-145 in your textbook.

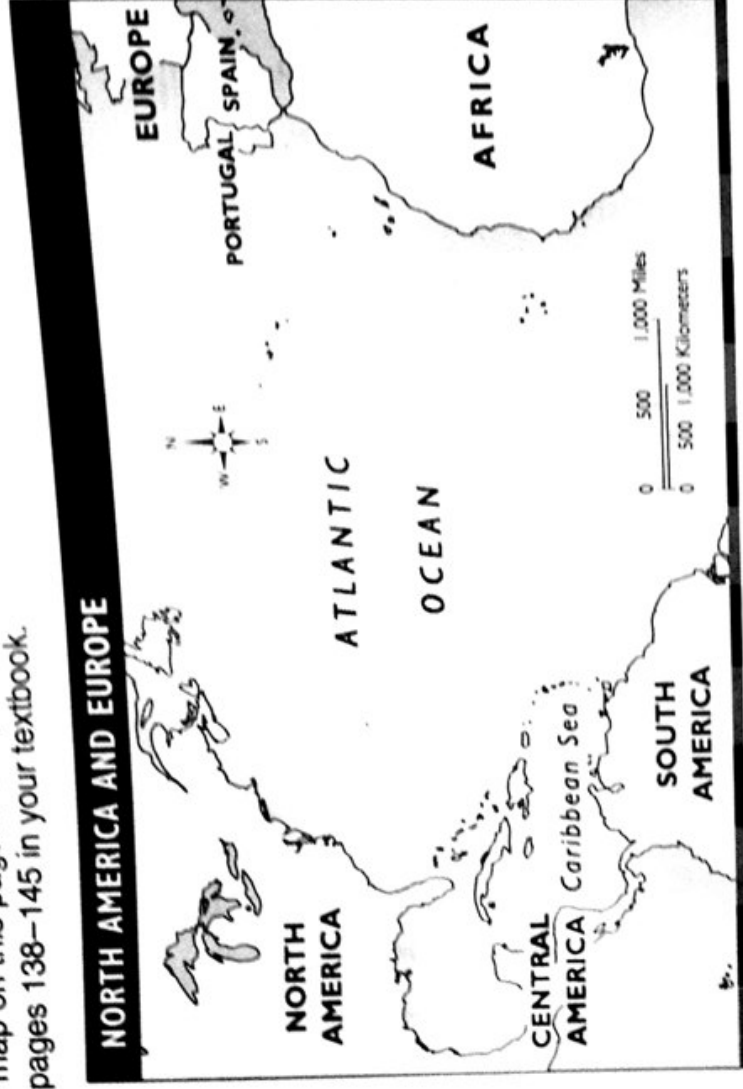

1. Draw the route of Columbus's first expedition to the Americas in red.

2. Why did Columbus make this expedition?

3. Locate the group of islands Columbus reached on his first expedition. Color them green. Then label them.

4. What did Columbus name the first island he visited in the Americas?

5. Draw the route of Columbus's second expedition in brown.

6. What do historians call the movement of people, plants, animals, and germs that resulted from these expeditions?

7. List two changes that occurred in the Eastern Hemisphere as a result of this exchange.

8. List two changes that occurred in the Americas as a result of this exchange.

THE FALL OF TENOCHTITLÁN

Read the paragraph below. It is part of an account written about Tenochtitlán by Hernando Cortés during his conquest of the Aztec. Then complete the activities. For additional background, refer to pages 148–153 in your textbook.

It [*the religious center*] is so large that in its precincts, which are surrounded by a wall, there could well lie a settlement of five hundred. Inside this area, about its edges, are fine buildings with large halls and corridors. There are at least 40 pyramids, very tall and well made; the largest has 50 steps leading up to the main body of the pyramid. . . . The stone masonry and the woodwork are equally good; they could nowhere be bettered. All the stonework inside the temples where they keep the idols is sculptured, and the woodwork is all carved in relief and painted with pictures of monsters and other figures and designs.

Editors, Time-Life Books, Aztecs: Reign of Blood & Splendor (Alexandria, VA: Time-Life Books, 1992)

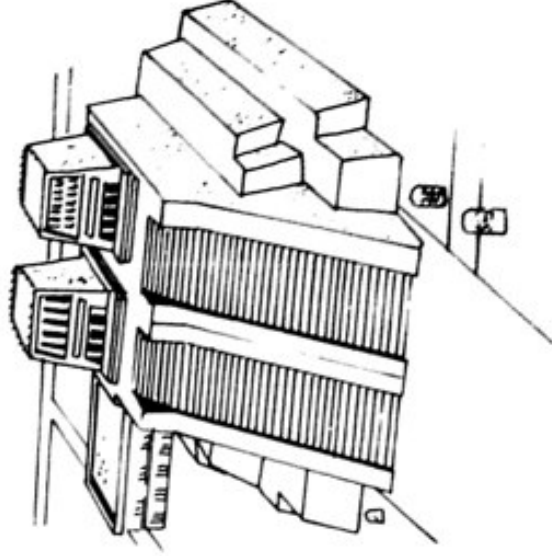

1. How do you think Cortés felt about what he had seen?

2. What was the name of the Aztec emperor at this time?

What happened to him? _____

3. List two reasons why Cortés and his Spanish soldiers were able to conquer Tenochtitlán and the Aztec empire.

4. What happened to Tenochtitlán after it fell to Cortés?

5. What did the Spanish call their new colony? _____

6. What did Tenochtitlán become known as? _____

READING HISTORICAL MAPS

The historical map below shows the routes of some Spanish explorers in North America. Use the map to complete the activities on this page. For help, you can refer to pages 154–155 in your textbook.



- List two clues that tell you this is an historical map.

 - List the names of the explorers whose routes are shown on the map.

 - What part of North America did Francisco Coronado explore? Circle your answer.
 southeast southwest
 northeast northwest
 - What major river in the American southeast did Hernando De Soto cross?

 - During what years did Cabeza de Vaca explore Mexico?

 - What present-day state did Ponce de León explore, and in what year did he explore it?

- What island in the Caribbean Sea did he sail from?

Name: _____

Use with pages 156–161.

LIFE IN NEW SPAIN

Look at each picture and read its caption. Then, in the space provided, tell what life was like in New Spain for the people shown in the picture. For help, you can refer to pages 156–161 in your textbook.

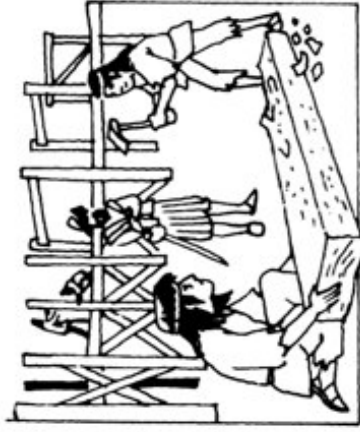

Indians at work on an encomienda

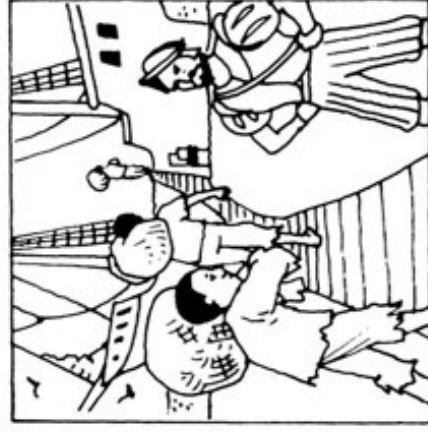

Enslaved Africans loading a ship



Spanish living in Mexico City

Macmillan/McGraw-Hill

FINDING AND USING NEW WORDS

Find the term that is hidden in each group of letters. Write the term on the line.

1. Cross out these letters: d, e, f, g.

e f c g d o l e f d o e n g y

2. Cross out these letters: g, l, p, s.

s e n l c g o m p s l i e n g d s l a

3. Cross out these letters: a, b, c.

a e x b c p e d a i t b i c o n a

4. Cross out these letters: d, e, g, u.

d e m i g u s e d s i o d u g n d a r e u y

5. Cross out these letters: f, k, p.

f C o k p l u p m b f i a k n e p x c h k a f n g p k e

6. Cross out these letters: b, e, w.

c w e o n e b q u e i s e w t b a d e o w r

Write each term from above next to its meaning. For help, you can look back at Chapter 6 in your textbook.

- | | |
|-------------------------------------------------------------------------------------------------------------|-------|
| 7. a journey made for a special purpose | _____ |
| 8. a settlement far away from the country that rules it | _____ |
| 9. the movement of people, plants, animals, and germs across the Atlantic Ocean during the time of Columbus | _____ |
| 10. a soldier who conquered new lands for Spain | _____ |
| 11. a very large piece of land granted by Spain to certain Spanish colonists | _____ |
| 12. a person who teaches his or her religion to others who have different beliefs | _____ |